

© COPYRIGHT 1973 BY AMP INCORPORATED, HARRISBURG, PA.
ALL INTERNATIONAL RIGHTS RESERVED. AMP INCORPORATED PRODUCTS
COVERED BY U. S. AND FOREIGN PATENTS AND/OR PATENTS PENDING.

REVISIONS					
REV	ZONE	LTR	DESCRIPTION	DATE	APPROVED
		O	RELEASE		
		A	REVISED PER ECN 2161	5-24-78	DM
		B1	REV ECN 203	6-4-78	DM
		B2	REV ECN 1963	6-10-78	SB
		B	RE-RELEASE - 7	8-15-89	DM
		C	ADDED - 6 & - 8 PER 2745 & AR2373	4-18-89	MP
		D	REV LOC & DIST AD-471	11-29-89	BF
		E	OBS - 8 PER 0010-0724-93	8-12-93	SAS
		F	REV PER 0010-1545-93	1-10-94	SAS
		G	REV PER 0010-1125-94	12-14-94	JH
		H	REV PER 0010-0947-96	6-3-96	CB/JH
		J	REV PER 063C-0062-00	11 FEB 08	MZ

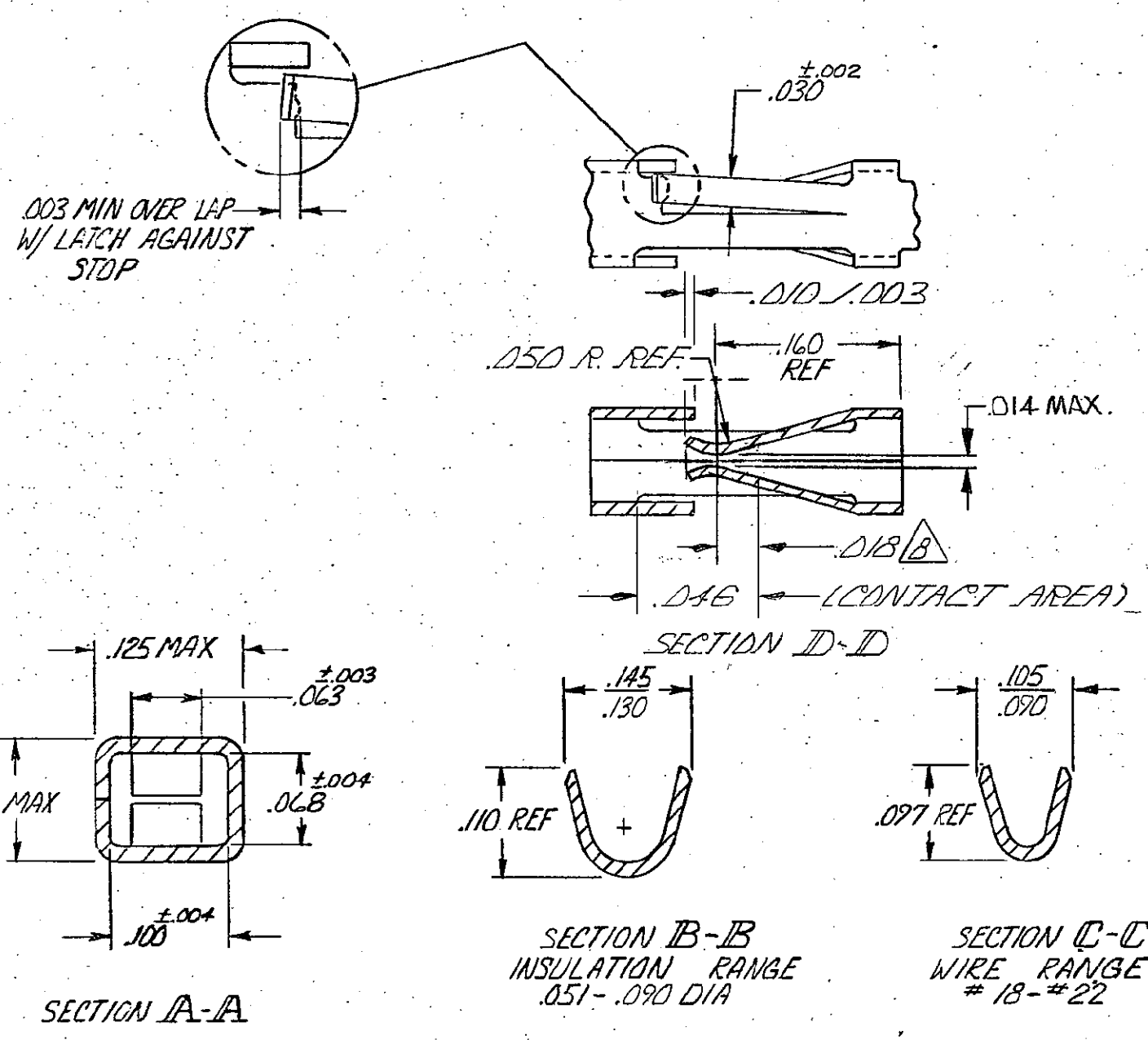
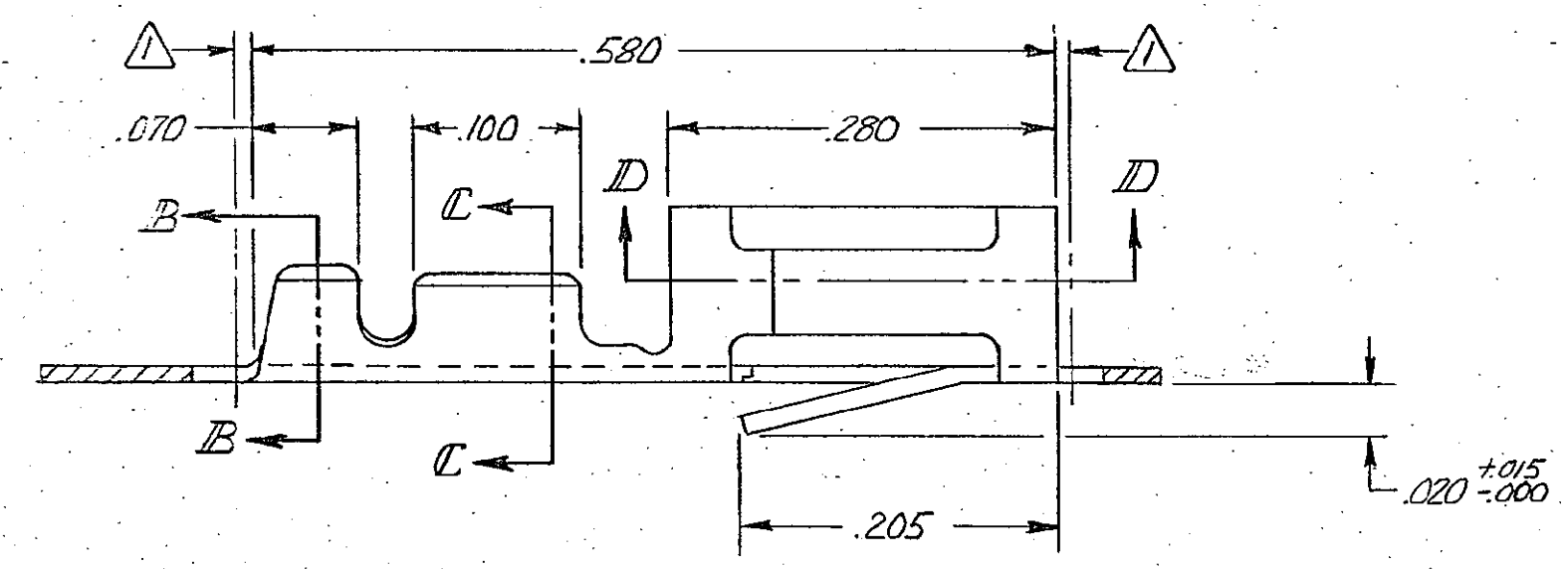
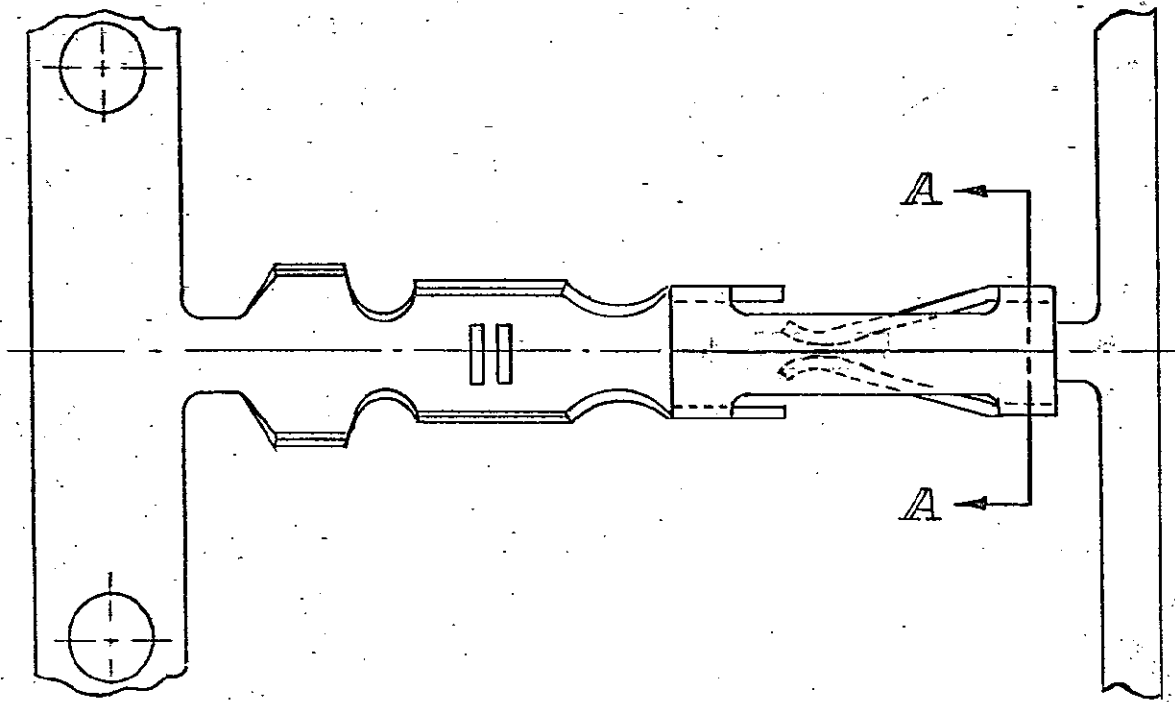

- 1. .010 MAX CUT-OFF TAB FOR LOOSE PIECE.
- 2. GOLD FLASH OVER .000050 NICKEL ENTIRE CONTACT, .000015 GOLD ON CONTACT AREA
- 3. GOLD FLASH OVER .000050 NICKEL ENTIRE CONTACT .000030 GOLD ON CONTACT AREA.
- 4. .000016 MIN TIN.
- 5. LUBRICATED
- 6. .000015 GOLD ON CONTACT AREA, .000050-.000100 BRIGHT TIN-LEAD ON TERMINATION AREA, ALL OVER .000050 NICKEL ENTIRE TERMINAL.
- 7. .000030 GOLD ON CONTACT AREA, .000050-.000100 BRIGHT TIN-LEAD ON TERMINATION AREA, ALL OVER .000050 NICKEL ENTIRE TERMINAL.
- 8. POINT OF MEASUREMENT FOR PLATING THICKNESS.
- 9. OBSOLETE PART NUMBER
- 10. .000030 GOLD OVER NICKEL ON ENTIRE CONTACT.
- 11. SUPERSEDED BY 102099-2

10	102103-6A	102099-8
7	102103-5	102099-7
6	102103-4	102099-6
4	102103-3	102099-5
3	102103-2	102099-2
2	102103-1	102099-1
FINISH	LOOSE PIECE P/N	PART NO

UNLESS OTHERWISE SPECIFIED DIMENSIONS ARE IN INCHES. TOLERANCES ON: DECIMALS ±.005 ANGLES ±	CONTRACT NO	AMP INCORPORATED Harrisburg, Pa.	
	DR <i>Tom Radwin</i> 4-12-78	NAME CONTACT, MOD I, RECEPTACLE, CRIMP SNAP-IN, STD. PRESSURE, # 18 - # 22 AWG, SIDE FEED	
	CHK <i>B. H. H. H.</i> 4-27-78	MATERIAL PHOS. BRONZE	
	APPD <i>A. J. J.</i> 4/28/78	FINISH SEE TABLE	
	APPD <i>B. Bennett</i> 5/1/75	DSGN APPD	OTHER APPD
		SIZE C	CODE IDENT NO 00779
		DRAWING NO 102099	
		SCALE	SHEET